

Sept. 1, 1964

C. L. FENDER

3,147,447

TONE CONTROL CIRCUIT

Filed Feb. 6, 1961

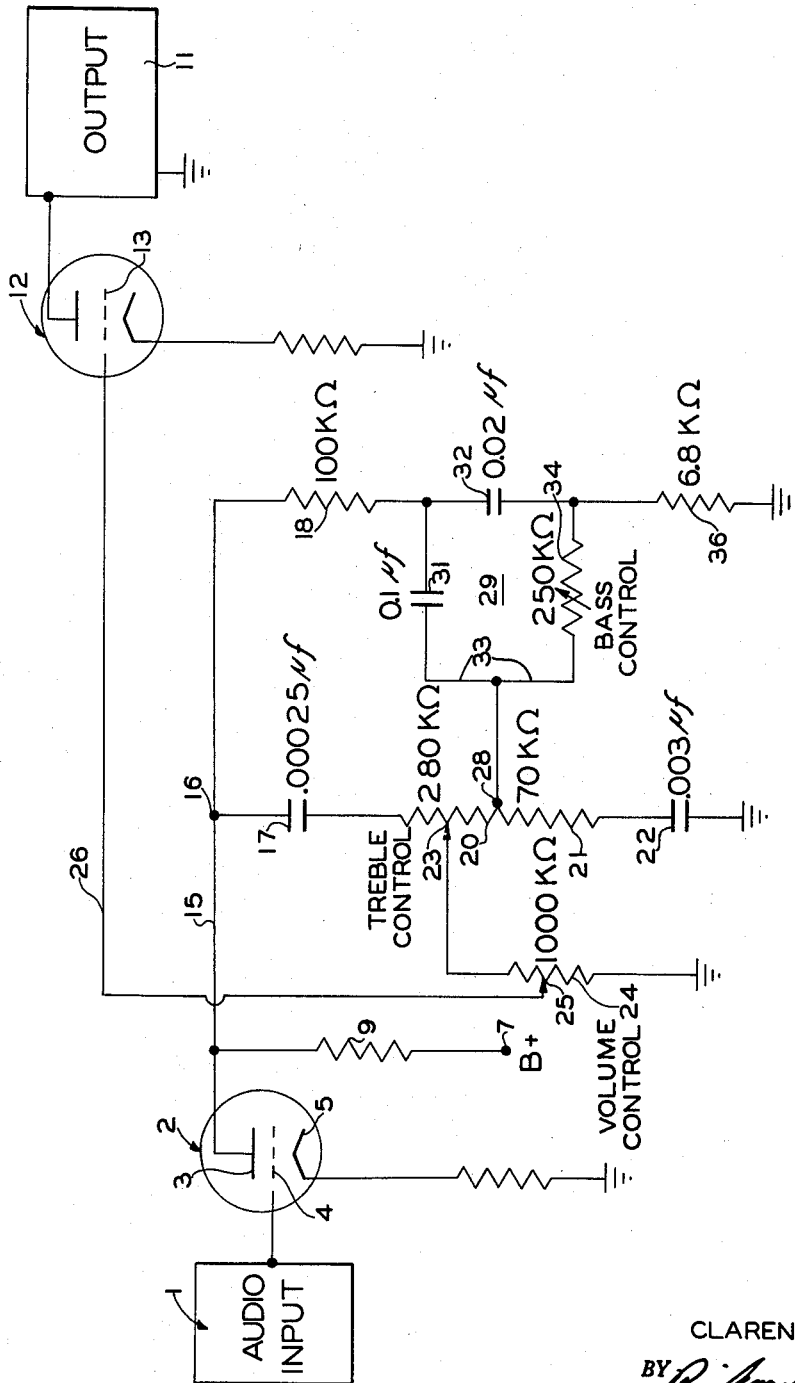

INVENTOR.
CLARENCE L. FENDER

BY *Richard L. Jury*

ATTORNEY

1

2

3,147,447

TONE CONTROL CIRCUIT

Clarence L. Fender, 2212 E. Revere, Fullerton, Calif.
 Filed Feb. 6, 1961, Ser. No. 87,304
 5 Claims. (Cl. 330-180)

This invention relates to a tone control circuit, and particularly to a tone control circuit for electrical musical instruments such as electric guitars and the like.

An object of the invention is to provide a tone control circuit which permits achievement of a brilliant high-frequency response without resulting in substantial distortion due to phase-shift and other effects.

A further object is to provide a tone control circuit in which phase-shift effects are much less pronounced and damaging than in prior-art tone control circuits.

A further object is to provide a tone control circuit in which the need for a coupling capacitor, with attendant phase-shift effects, is eliminated.

A further object is to provide a tone circuit having substantially separate control elements for the high and low frequencies, and which may be set in such manner that the response is characterized by substantially equal amounts of the high and low-frequency components.

These and other objects and advantages of the invention will be more fully set forth in the following specification and claims, considered in connection with the attached single-figure drawing to which they relate.

Representative values of resistance and capacitance are incorporated in the drawing in order to present a detailed example of one operative form of the invention. It is to be understood, however, that various other values may be employed, the important consideration normally being relative values as distinguished from absolute values.

Referring to the drawing, an audio input (which may, for example, be associated with an electric guitar) is schematically represented at 1 and may include one or more amplifier stages with appropriate coupling capacitors or resistors. The triode vacuum tube of the last amplifier stage is shown at 2, and has a plate 3, grid 4, and cathode 5. A conventional source of direct plate voltage is indicated at 7, being connected to plate 3 through a resistor 9.

The audio output is indicated at 11 and may also include an amplifier stage, there being a triode vacuum tube 12 associated with the output and adapted to effect variations in output voltage in response to variations in the voltage impressed upon the grid 13 of the tube.

A lead 15 is connected from plate 3 to a junction point 16. Such junction point is connected to one terminal of a very low-value capacitor 17, which passes only the higher-frequency components in substantial amount, and also to one terminal of a resistor 18.

The remaining terminal of capacitor 17 is connected to the winding 20-21 of a potentiometer, such winding having a substantial resistance value which, in the illustrated example, is 350 kilohms. The other end of the potentiometer winding is connected to ground through a capacitor 22 which, although still low in value, has a capacitance approximately one order of magnitude higher than that of capacitor 17.

Potentiometer winding 20-21 forms, together with its slider 23, the treble control element of the tone control circuit. Such slider 23 is connected to ground through a potentiometer winding 24 having a very high value. The slider 25 associated with winding 24 is connected through a lead 26 to grid 13 of vacuum tube 12. Potentiometer 24-25 may be termed the volume control element.

It is a feature of the invention that potentiometer winding 20-21 is tapped, as indicated at 28, at a point intermediate the ends thereof. More specifically, the tap is

disposed at such a location that the great majority of the resistance in the winding (resistor element 20-21 is between tap 28 and capacitor 17, only a minority of the resistance being between the tap and capacitor 22. In the illustrated example, tap 28 is so located that the resistance between it and capacitor 17 is approximately four times the resistance between it and capacitor 22.

A bass-control network 29 is provided, being connected to tap 28, to ground, and to junction point 16. More specifically, the illustrated bass-control network 29 comprises two capacitors 31 and 32 both of which have terminals directly connected to resistor 18, the former capacitor having a value a substantial number of times that of the later. The remaining terminal of the relatively high-value capacitor 31 is connected through a lead 33 to the previously-indicated potentiometer tap 28 and also to one terminal of a relatively high-value rheostat 34. The remaining terminal of rheostat 34, which may be termed the bass control element, is connected to the remaining terminal of capacitor 32. The junction between capacitor 32 and rheostat 34 is connected through a relatively low-value resistor 36 to ground.

It is pointed out that the combined impedance of elements 17, 20-21 and 22 is very high in comparison to the combined impedance of elements 18, 32 and 36. At low frequencies this impedance difference is enormous. Even at 1000 c.p.s., the combined impedance of elements 17, 20-21 and 22 is at least on the order of ten times that of elements 18, 32 and 36.

Operation

The operation will first be described with reference to the higher-frequency components, and then with reference to the lower-frequency components. Of course, there is considerable overlapping, and the middle-frequency components respond in a manner intermediate that which will be described relative to the highs and lows.

Because of the above-stated impedance relationships, the major portions of the higher-frequency currents arriving at junction point 16 pass through resistor 18, capacitor 32 and resistor 36 to ground. The minor portions of such higher-frequency currents pass through the low-value capacitor 17, potentiometer winding 20-21 and capacitor 22 to ground. It is to be understood, however, that as the frequency increases, larger amounts of current flow through elements 17, 20-21 and 22 due to a lowering of the effective impedance of capacitors 17 and 22.

Assuming that the slider 23 is initially at the upper end of the resistor element 20, adjacent capacitor 17, a maximum treble response is obtained since all of the voltage present in elements 20-21 and 22 is impressed across the high-value resistor element 24 of potentiometer 24-25. A desired amount of this voltage is then picked off by the slider 25 and impressed upon the grid 13 of output tube 12. Because the setting of slider 25 determines the volume of not only the higher-frequency components but also the lower-frequency components, it will be assumed in the present discussion that the setting of slider 25 remains fixed.

A downward shifting of slider 23 progressively decreases the treble response since progressively smaller amounts of voltage are picked off elements 20-22 and are impressed across potentiometer winding 24. This is true even after the slider 23 is shifted downwardly past tap 28 onto the lower portion 21 of the potentiometer winding 20-21, despite the fact that there is a certain bleeding of high-frequency currents through the relatively large capacitors 31 and 32 and low-value resistor 36. When the slider 23 arrives at the lower end of winding portion 21, adjacent capacitor 22, the treble response becomes minimum.

A progressive treble control is thus obtained by shifting the treble slider between its maximum-treble position (up-

per end of winding portion 20) and its minimum-treble position (lower end of winding portion 21). It is an important feature of the invention that, when the slider 23 is at the upper end of winding portion 20, a very brilliant and powerful treble response is obtained. One reason for this is that the resistance of winding portion 20 acts as an isolating resistor to prevent excessive flow of current through capacitors 31 and 32 and resistor 36 to ground.

Referring next to the lower-frequency currents which arrive at junction point 16, these pass through resistor 18 since they are effectively blocked by the low-value capacitor 17. Because the capacitor 31 is much higher in value than capacitor 32, the major portions of the lower-frequency components which arrive at the lower end of resistor 18 pass through capacitor 31 to lead 33. Such lower-frequency components in lead 33 then divide, certain portions passing through tap 28, a part of winding 20-21, slider 23 and winding 24 to ground. The remaining portions of the lower-frequency components in lead 33 pass through bass-control rheostat 34 and resistor 36 to ground.

As the rheostat 34 is adjusted to increase the value of its resistance, a progressively larger bass response is obtained. This is because more current is caused to pass from lead 33 to slider 23 and thence through winding 24 to ground. Conversely, reduction in the resistance of rheostat 34 increases the amount of current passed through resistor 36 to ground, and reduces the bass response since a progressively smaller current is passed to tap 28 and thence through winding 24 to ground.

It is pointed out that the lower-frequency currents arriving at tap 28 are prevented from being grounded through winding portion 21 and capacitor 22, due to the relatively low value of capacitor 22. Thus, lower-frequency currents at tap 28 must pass primarily through rheostat winding 24 to ground.

The bass response is affected somewhat by the setting of the slider 23 of the treble control. However, as will next be explained, this effect is not great nor is it damaging. It is pointed out that the resistance of potentiometer winding 24 is very much larger than the resistance of either winding portion 20 or 21. Thus, variation in the resistance which is inserted between tap 28 and slider 23 is relatively small in comparison to the high resistance of winding 24. It follows that adjustment of slider 23 does not greatly affect the bass response.

It is also pointed out that when the slider 23 is relatively near capacitor 17, for maximum treble response, the effect is to insert substantially all of winding portion 20 in series with winding 24 and thus cause the bass response to be reduced. Thus, at least in this important range, the resistance inserted between tap 28 and slider 23 acts to effect some reduction in the bass response when maximum treble is desired.

Reference will now be made to the very important problem of phase shift in the tone control network. It will first be emphasized that phase-shift problems, and all distortion problems, are very critical with relation to amplifiers and tone control circuits for electrical musical instruments, such as electric guitars. Such problems are even more critical than they are in conventional high fidelity circuits such as are used for reproducing phonograph records. Thus, a tone control circuit which is adequate in a high fidelity system may be inadequate when employed in conjunction with an electric guitar or the like. The converse is not true, however, since a tone control circuit which works well with an electric guitar will also work very well in a high fidelity system for phonographs or the like.

Applicant has discovered that the phase-shift problem is greatly accentuated when a blocking capacitor must be employed between the plate 3 and junction point 16. Such blocking capacitors are conventionally required in order to prevent the D.C. voltage of source 7 from reaching grid 13 and also from reaching the control elements 34, 23 and

25. By this it is meant that a practical blocking capacitor, which has such a magnitude that it does not introduce numerous other problems, effects such a phase shift that its use in lead 15 is undesirable.

The need for such a blocking capacitor is completely eliminated by the present invention since the capacitors 17, 31 and 32 effectively prevent the voltage of source 7 from reaching the elements 13, 34, 23 and 25. Thus, not only is the phase shift problem introduced by conventional blocking capacitors eliminated, but the circuit requires one less component. Such use of frequency-dividing functioning capacitors as blocking capacitors, in place of an element which acts only as a blocking capacitor, is another important feature of the invention.

Various embodiments of the present invention, in addition to what has been illustrated and described in detail, may be employed without departing from the scope of the accompanying claims.

I claim:

1. A tone control system adapted to be interposed between an audio output and a source of audio-frequency signals having higher-frequency and lower-frequency components, said system comprising a potentiometer having a resistor element and a slider movable thereon, first circuit means including a low-value capacitor to connect one end of said resistor element to said audio source, second circuit means to connect the other end of said resistor element to ground, third circuit means to connect said slider to said audio output, a bass control network, fourth circuit means to connect said bass control network to said audio source, fifth circuit means to connect said bass control network to ground, and sixth circuit means to connect said bass control network to said potentiometer, said sixth circuit means including a tap on said resistor element, said bass-control network including first and second capacitors both connected to said fourth circuit means, said first capacitor having a value much higher than the value of said second capacitor, said bass-control network further including bass control means to regulate the passage to said fifth circuit means of signal which passed through said first capacitor.

2. The invention as claimed in claim 1, in which said first capacitor is connected between said fourth circuit means and said tap, in which said second capacitor is connected between said fourth circuit means and said fifth circuit means, and in which said bass control means is a rheostat connected between said tap and said fifth circuit means.

3. A tone control circuit adapted to be interposed between an audio output and a source of audio-frequency signals having higher-frequency and lower-frequency components, which comprises a potentiometer having a resistor element and a slider movable thereon, a first capacitor connected between one end of said resistor element and said audio source, a second capacitor connected between the other end of said resistor element and ground, circuit means to connect said slider to said audio output, a tap associated with said resistor element and relatively adjacent said other end thereof whereby the resistance between said tap and said first capacitor is a number of times that of the portion of said resistor element between said tap and said second capacitor, a first resistor connected to the side of said first capacitor opposite said resistor element, a bass control network connected to said resistor and to said tap, and means including a second resistor to connect said bass control network to ground, said bass control network including a third capacitor connected between said first resistor and said second resistor, a fourth capacitor having one terminal connected to the junction between said first resistor and said third capacitor and the other terminal connected to said tap, and a rheostat having one terminal connected to the junction between said third capacitor and said second resistor and the other terminal connected to said tap, said fourth capacitor having a value much higher than that of said third capacitor.

5

4. The invention as claimed in claim 3, in which said source of audio-frequency signals includes a vacuum tube, and in which said first capacitor and said third and fourth capacitors effect blocking of the D.C. plate voltage on said vacuum tube so that such voltage does not reach said bass control network or said potentiometer whereby a blocking capacitor for such voltage is not required.

5. A tone control circuit adapted to be interposed between an audio output and a source of audio-frequency signals having higher-frequency and lower-frequency components, which comprises a potentiometer having a resistor element and a slider movable thereon, a first capacitor connected between one end of said resistor element and said audio source, a second capacitor connected between the other end of said resistor element and ground, circuit means to connect said slider to said audio output, a tap associated with said resistor element and relatively adjacent said other end thereof whereby the resistance between said tap and said first capacitor is a number of times that of the portion of said resistor element between said tap and

5

10

15

20

6

said second capacitor, a first resistor connected to the side of said first capacitor opposite said resistor element, a bass control network connected to said resistor and to said tap, and means including a second resistor to connect said bass control network to ground, said means to connect said slider to said audio output including a vacuum tube having its grid connected to the slider of an additional potentiometer, said additional potentiometer having its resistor element connected between ground and said slider of said first-mentioned potentiometer.

References Cited in the file of this patent

UNITED STATES PATENTS

2,322,558	Bachman	June 22, 1943
2,578,541	Hammond	Dec. 11, 1951
2,680,231	Reed	June 1, 1954
2,680,232	Claras et al.	June 1, 1954
2,802,063	Fine et al.	Aug. 6, 1957
2,900,609	Estkowski	Aug. 18, 1959