

[54] **SINGLE PICKUP FREQUENCY CONTROL FOR STRINGED INSTRUMENT**

[72] Inventor: **Quilla H. Freeman**, 1050 Gardner Street, Hollywood, Calif. 90046

[22] Filed: **Dec. 21, 1970**

[21] Appl. No.: **100,137**

[52] U.S. Cl. **84/1.15, 84/1.16**
 [51] Int. Cl. **G10h 3/00**
 [58] Field of Search **84/1.01, 1.14-1.16, 84/267**

[56] **References Cited**

UNITED STATES PATENTS

2,119,584	6/1938	Knoblauch.....	84/1.15
Re20,070	8/1936	Lesti.....	84/1.15
2,896,491	7/1959	Lover.....	84/1.16 X
3,035,472	5/1962	Freeman.....	84/1.16

3,066,567	12/1962	Kelley.....	84/1.16
2,455,046	11/1948	De Armond.....	84/1.15
2,892,371	6/1959	Butts.....	84/1.16
2,209,016	7/1940	Dickerson.....	84/1.15

Primary Examiner—Lewis H. Myers
Assistant Examiner—U. Weldon
Attorney—J. Calvin Brown

[57] **ABSTRACT**

A single pickup frequency control is placed transversely below the strings of an instrument such as a banjo, guitar, mandolin or other vibrating metal instrument. The pickup comprises a bar magnet, the poles of which are situated at the top and the bottom faces thereof. A divider surrounds the magnet transversely of and parallel with the two polar faces of the magnet. Wire coils surround the magnet on each side of the divider plate and the coils are so connected that the electrical path of one coil is clockwise while the electrical path of the other coil is counterclockwise. One end of the top and of the bottom coils leads to an amplifier connected to a loud speaker.

3 Claims, 5 Drawing Figures

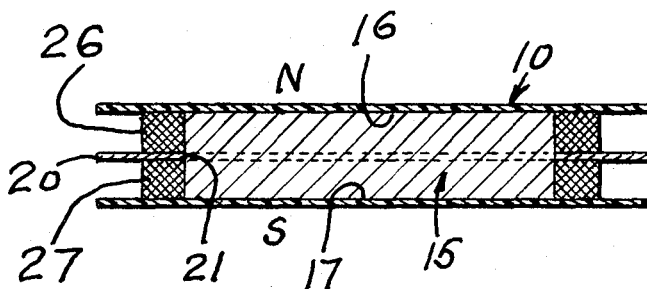

FIG. 1.

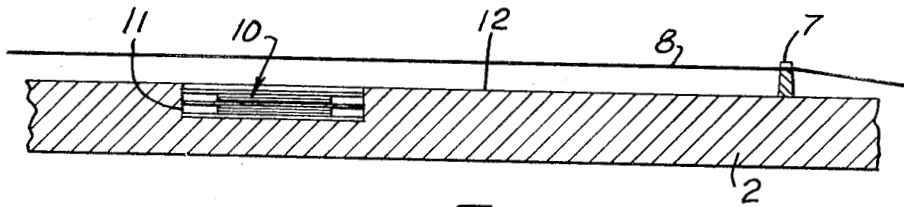
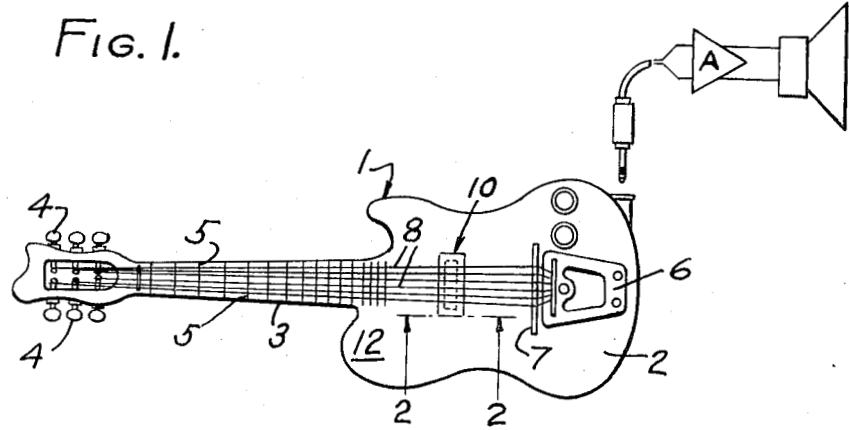

FIG. 2.

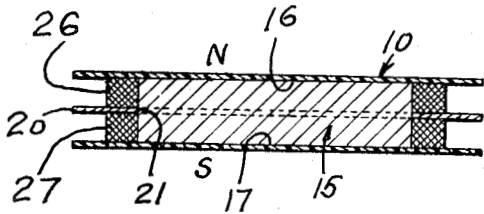

FIG. 3.

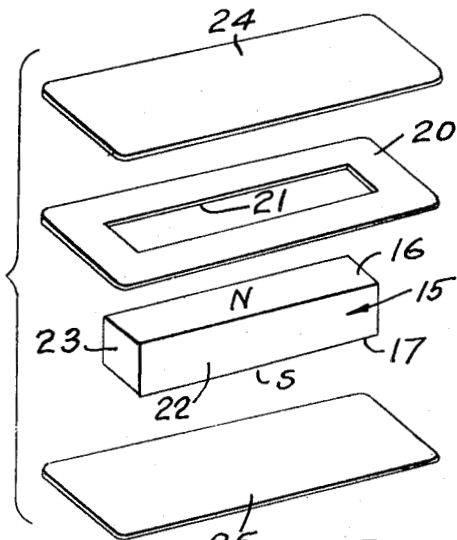

FIG. 4.

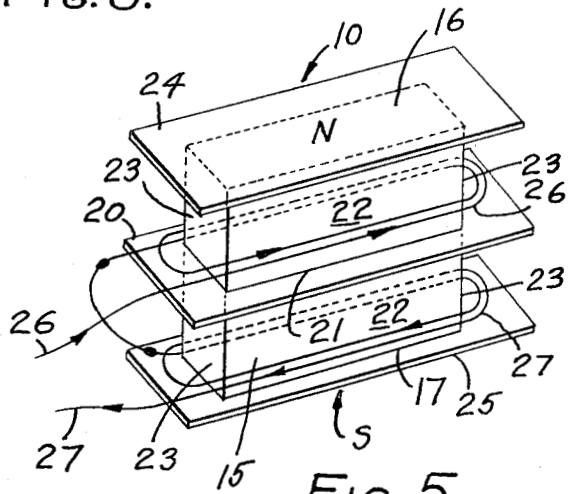

FIG. 5.

INVENTOR,
QUILLA H. FREEMAN;
BY *Galvin Brown,*
ATTORNEY

SINGLE PICKUP FREQUENCY CONTROL FOR STRINGED INSTRUMENT

BACKGROUND OF THE INVENTION

1. Field of the Invention

Stringed instruments such as banjos, guitars, mandolins and the like require amplifying means for music produced by a plucking of the strings. However, it has been found that extraneous objects such as electrical devices in proximity to the pickup creates undesirable currents which produce a hum in the amplifier and one of the objects of the present invention is to provide a pickup wherein no hum will be present in the amplifier nor will there be distortion with the result that there will be a quality signal of high gain, high volume without any out of phase frequency resulting in a clear sound and with all harmonics in phase.

2. Description of the Prior Art

The prior art as the inventor knows it has required separate pickups for the strings as well as various controls for the pickups such as shown in patents to Fender, U.S. Pat. Nos. 2,976,755; 3,147,332; 3,177,283 3,290,424. Also, may be mentioned the patent to Butts, U.S. Pat. No. 2,892,371, and Lover, U.S. Pat. No. 896,491. All of these patents introduce considerable complication in the installation of the pickup devices in the musical instruments as well as it being quite expensive to fabricate and install.

SUMMARY OF THE INVENTION

With the present invention I utilize a single pickup rather than multiple or split pickups as shown in the prior art just referred to. A single pickup may be installed in the stringed instrument slightly below or flush with the top surface of the instrument and transversely of the strings of the instrument. A number of stringed instruments as used today have solid bodies rather than the usual bodies that have a sound or resonant chamber. However, either form, solid or resonant, may be used and assuming that a solid body is utilized, the body is provided with the usual neck carrying spaced frets and keys, there being a bridge and a tail piece on the top surface of the body and between the tail piece and keys are steel strings, usually six in number, for a banjo or guitar, etc. Between the bridge and the neck is placed the single pickup. This pickup is relatively thin and comprises a bar magnet the top and bottom faces of which contain the north and the south poles respectively. Usually the magnet is of the permanent type and may be the well-known plastic magnet. In the present instance the plastic magnet is a light prism preferably a rectangular parallelepiped. A spacer or divider plate surrounds the magnet and equally divides the lateral faces and the bases thereof to provide upper and lower sections without cutting the magnet. The spacer or divider plate is relatively thin and slotted so as to encompass the magnet with the plate projecting outwardly and beyond the bases and lateral faces of the magnet. The plate may be formed of various materials such as a magnetic material such as iron, or in some instances a non-magnetic material may be utilized. When the spacer or divider plate is surrounding the magnet, coils surround the magnet above and below the spacer or divider plate. Each coil has the same wire size and preferably has the same number of turns, the coils being connected at one end of each coil so that current flows clockwise in one coil and counterclockwise in the other coil. The coils are enclosed by coil plates at the top and bottom of the magnet. These plates may be of paper or other material.

BRIEF DESCRIPTION OF THE DRAWING

FIG. 1 is a plan view of a guitar incorporating the invention;
FIG. 2 is a fragmentary, sectional view on an enlarged scale, taken on the line 2—2 of FIG. 1;

FIG. 3 is a transverse sectional view on an enlarged scale, of the pickup;

FIG. 4 is a separated perspective view, on an enlarged scale, of the various elements entering into the pickup construction; and,

FIG. 5 is illustrative of the coils surrounding the magnet and the connection of the coils.

BRIEF DESCRIPTION OF THE PREFERRED EMBODIMENT

In FIG. 1, 1 designates a stringed instrument which, as previously stated, may be a banjo, guitar, mandolin or other instrument. The instrument 1 has a body 2, a neck 3 and a portion connected to the end of the neck carrying keys 4. The neck is provided with spaced apart frets 5. The body is provided with a tail piece 6 and a bridge 7 forward of the tail piece. The tail piece secures one end of the strings designated generally as 8, which strings are passed over the bridge and the frets and secured to the keys 4. In the present instance there are six strings and the strings are usually of steel.

The pickup device of the invention is shown at 10 and lies substantially transversely of the strings 8. The pickup 10 preferably is recessed in the body 2 as shown in FIG. 2 at 11. The top surface of the pickup is substantially flush with or slightly below the top surface 12 of the body. It will be observed that the pickup extends beyond the outside strings as shown in FIG. 1. Usually, the strings extend approximately one-half inch above the top surface of the body. In the present instance the body is of the solid type rather than the type of body that is provided with a resonant chamber. However, either form of body may be utilized with the present invention. The pickup 10 comprises a magnet 15, in the present instance of rectangular parallelepiped form, the top and bottom faces 16 and 17 respectively providing north pole and south pole portions. In other words, the permanent magnet is magnetized transversely from top face to bottom face rather than longitudinally of its length so that one face of the magnet constitutes a north pole and the other face constitutes a south pole.

A spacer or divider plate 20 preferably formed of magnetic material is slotted centrally at 21 so as to surround the magnet paralleling the polar faces 16 and 17 and dividing the faces 22 and 23 and the bases as illustrated in FIG. 3. Plates of cardboard or fiber 24 and 25 of a width and length substantially equal to the spacer or divider plate 20 are provided for the top and bottom faces 16 and 17 of the magnet. In the space included between the plates 24 and 25 and the divider plate are coils 26 and 27 having equal wire size and turns. These coils surround the magnet and are separated by the divider plate 20. As shown in FIG. 5 the coil 27 connects with coil 26 so that electric current flows in a clockwise direction in coil 27 and counterclockwise in coil 26. One end of each coil leads to an amplifier loud speaker assembly. The coil 26 lies in the north pole flux while coil 27 lies in the south pole flux of the magnet 15.

It may be remarked that the more turns of wire per coil increases the resistance and when there is an increase in resistance with ordinary pickups, not the pickup of this invention, tone distortion is created when amplified. With the present invention, the coil arrangement of two coils surrounding the magnet and isolated from each other by the spacer or divider plate, allows the number of turns in the coil to be increased without causing distortion of tone and with increased signal strength.

When the pickup is positioned as shown in FIGS. 1, 2 and 3, beneath the strings 8, a plucking of a string varies the magnetic field caused by the permanent magnet 15 so that vibration of the string induces an electric current in the coils 26 and 27 and this electric current in turn is amplified and passed to a loud speaker. I have determined by experiment that the spacer or divider plate 20 by being formed of magnetic material maintains the coil 26, for instance, in the flux of the north pole and the coil 27 in the flux of the south pole. The north pole flux also extends to the south pole and to the divider plate.

I have found that external magnetic disturbances such as a hum or other noise is eliminated because the opposite current flow in the coils 26 and 27 cancels any electrical signals produced by external magnetic disturbances in the pickup and

3

4

that a clear frequency is delivered to the amplifier resulting in no distortion of tone.

It has been found that two identical bar magnets having north and south poles as shown for magnet 16, separated by a plate such as 20, with each magnet surrounded by wire coils, electrically connected, functions in the same manner as described for pickup 10.

I claim:

1. A stringed musical instrument such as a guitar, having a body provided with a face, a neck connected to the body and spaced apart magnetizable strings extending over the neck and over the face with means for connecting ends of the strings to the body and opposite ends of the strings to the neck, the improvement comprising: a single pickup device secured transversely beneath the strings to the face of the body, said single pickup device having a permanent magnet, the opposite faces of said magnet constituting north and south poles and one pole of which is directly beneath all strings, a plate of magnetic

material dividing the magnet laterally, said plate surrounding the magnet from end to end and formed with a central slot having the same outline as the outline of the magnet, for receiving the magnet therein, and separate coils surrounding the magnet on opposite sides of the plate, the coils being electrically connected at one end of each thereof, electric current in one coil flowing clockwise and in the other coil counterclockwise the other ends of the coils leading to an amplifier and loud speaker assembly.

2. The device of claim 1, wherein said plate parallels the polar faces of the magnet and extends outwardly beyond the bases and lateral faces of the magnet.

3. The device of claim 1, with the addition of plates of non-magnetic material on the top and bottom faces of said magnet said non-magnetic plates being of a width and length substantially equal to the plate dividing the magnet laterally.

* * * * *

20

25

30

35

40

45

50

55

60

65

70

75