

Blues Express Plus Version A9b

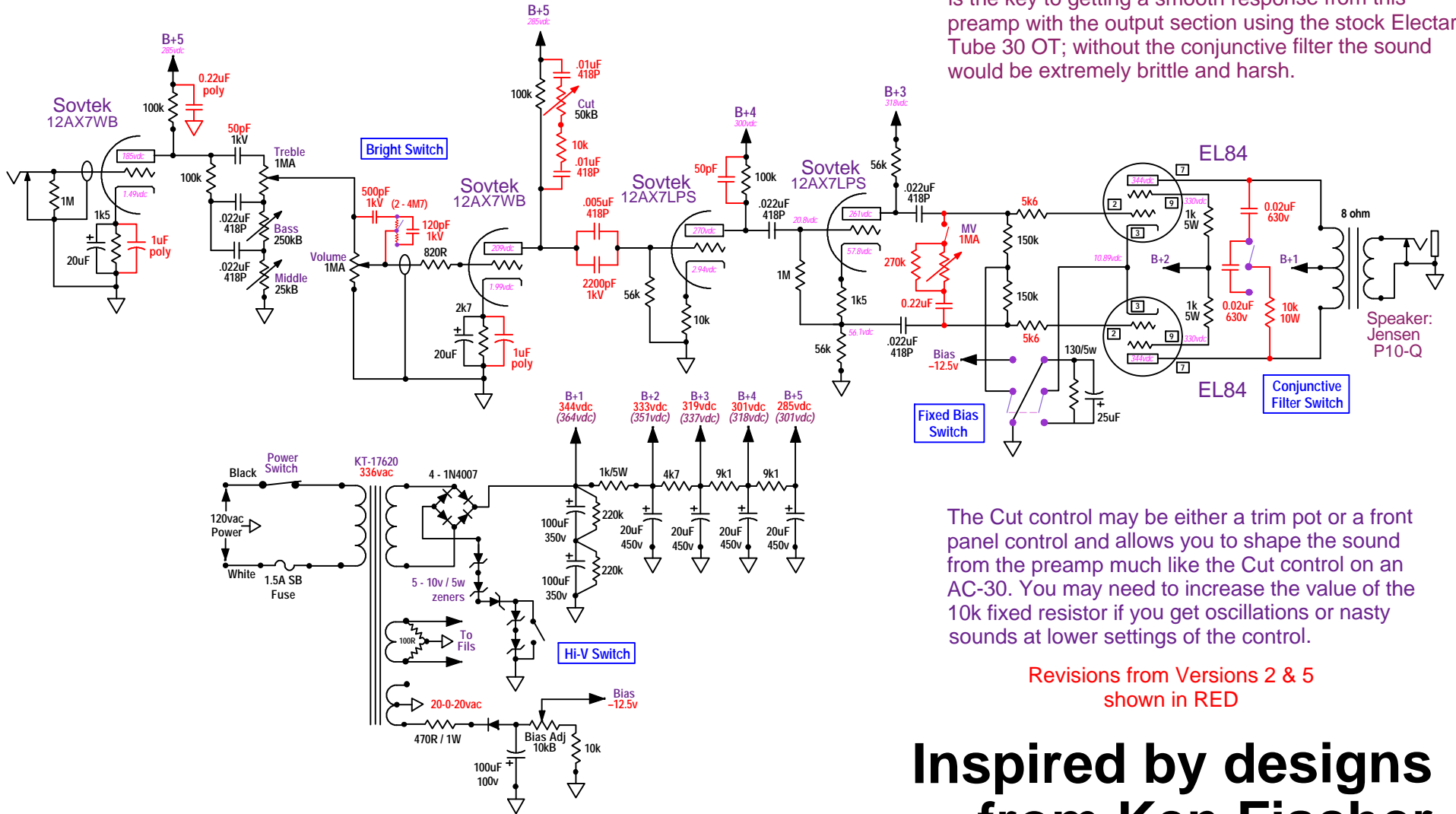

The Blues Express Plus is a radical reworking of the Blues Express chassis along the lines of more traditional Trainwreck designs. The conjunctive filter is the key to getting a smooth response from this preamp with the output section using the stock Electar Tube 30 OT; without the conjunctive filter the sound would be extremely brittle and harsh.

The Cut control may be either a trim pot or a front panel control and allows you to shape the sound from the preamp much like the Cut control on an AC-30. You may need to increase the value of the 10k fixed resistor if you get oscillations or nasty sounds at lower settings of the control.

Revisions from Versions 2 & 5 shown in RED

Inspired by designs from Ken Fischer