

Blues Express Plus Version A9d

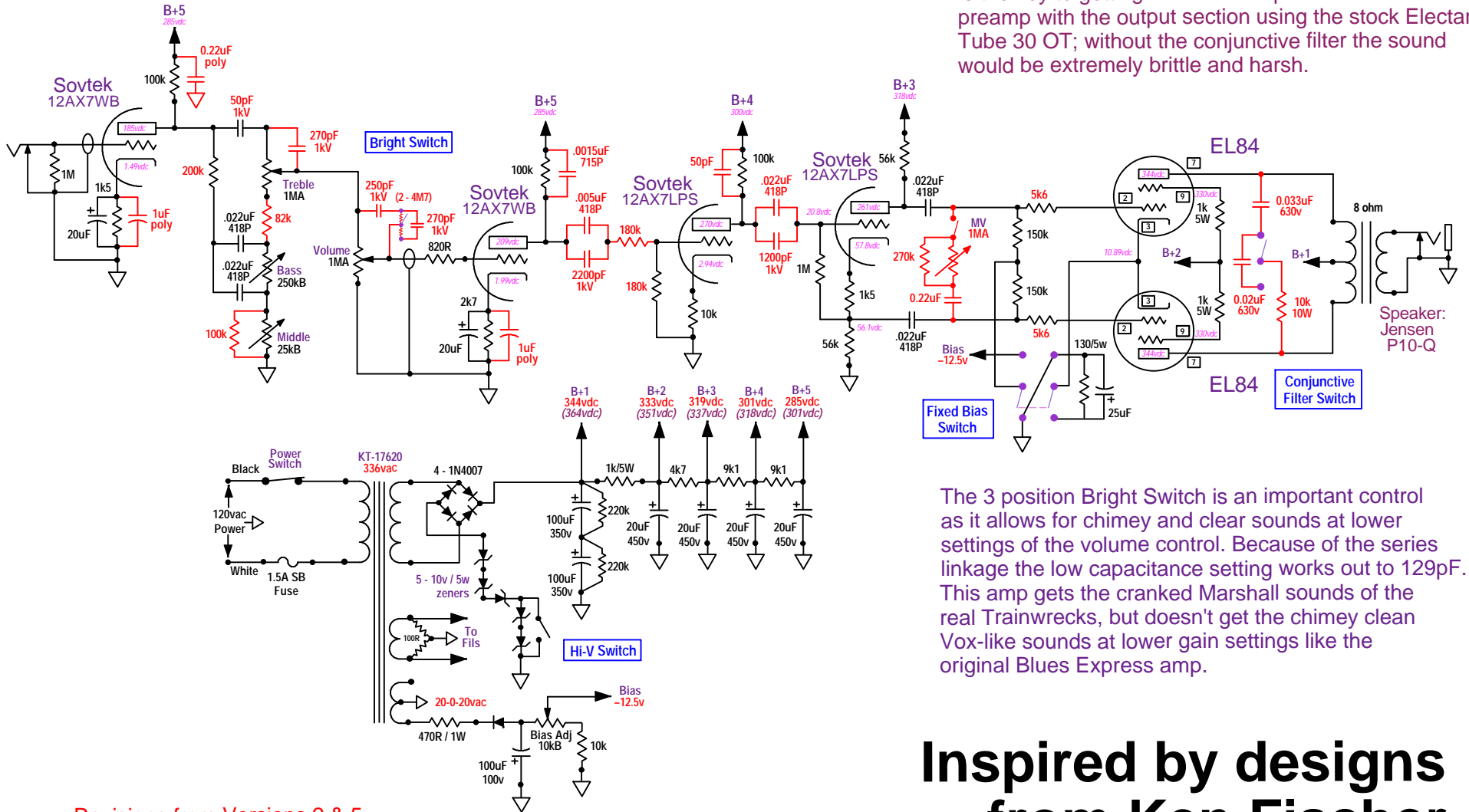

Revisions from Versions 2 & 5
shown in RED

The Blues Express Plus is a radical reworking of the Blues Express chassis along the lines of more traditional Trainwreck designs. The conjunctive filter is the key to getting a smooth response from this preamp with the output section using the stock Electar Tube 30 OT; without the conjunctive filter the sound would be extremely brittle and harsh.

The 3 position Bright Switch is an important control as it allows for chimey and clear sounds at lower settings of the volume control. Because of the series linkage the low capacitance setting works out to 129pF. This amp gets the cranked Marshall sounds of the real Trainwrecks, but doesn't get the chimey clean Vox-like sounds at lower gain settings like the original Blues Express amp.

Inspired by designs from Ken Fischer

Rev.05-16-01