

The Blues Express Version A5h

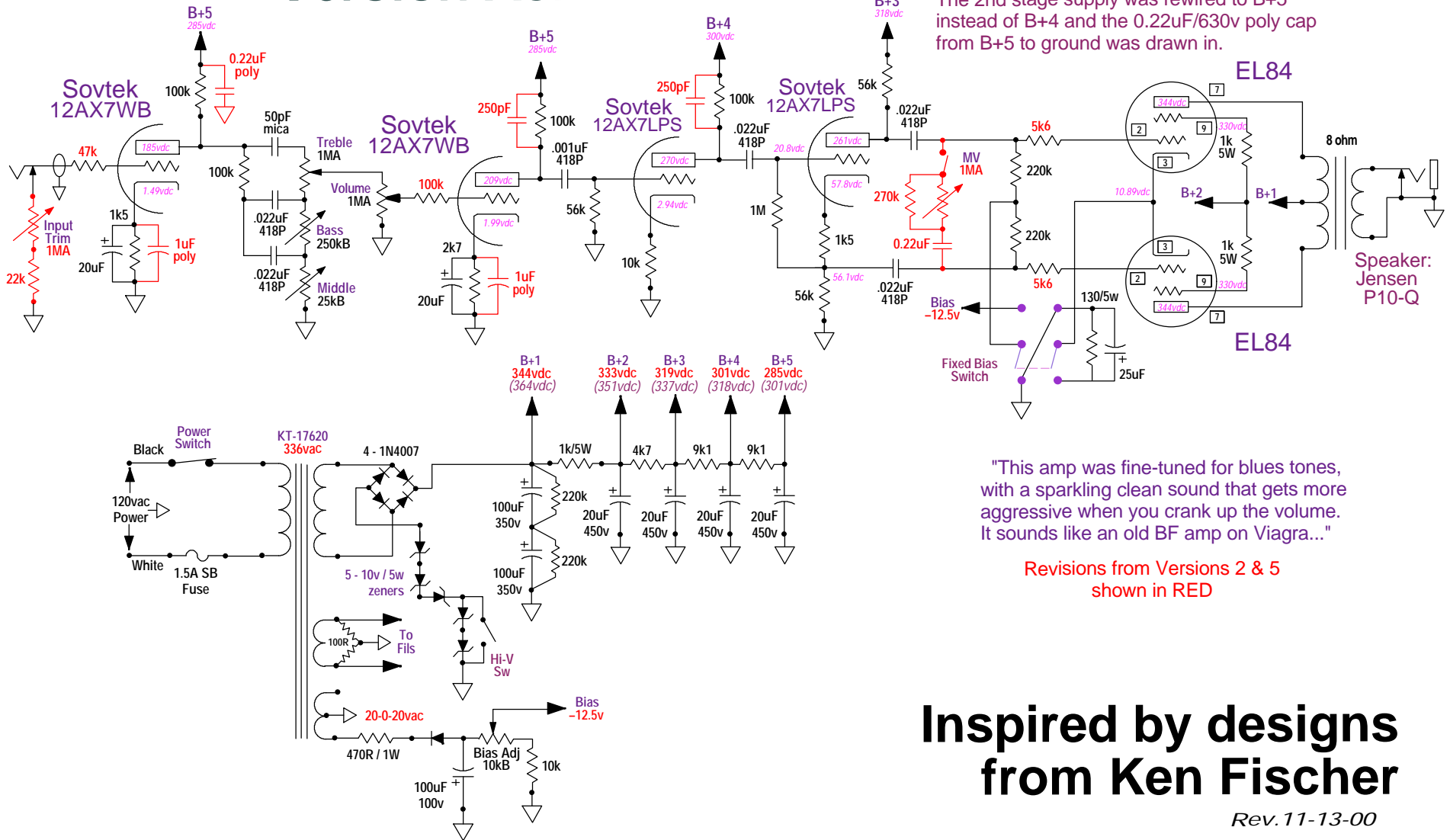

This is the final version of the Blues Express amp. The zener limiting circuit was removed and a modified cross-line MV was installed in its place. The bias/grid load resistors were returned to their original value of 220k. The 2nd stage supply was rewired to B+5 instead of B+4 and the 0.22uF/630v poly cap from B+5 to ground was drawn in.

"This amp was fine-tuned for blues tones, with a sparkling clean sound that gets more aggressive when you crank up the volume. It sounds like an old BF amp on Viagra..."

Inspired by designs from Ken Fischer

Rev. 11-13-00