

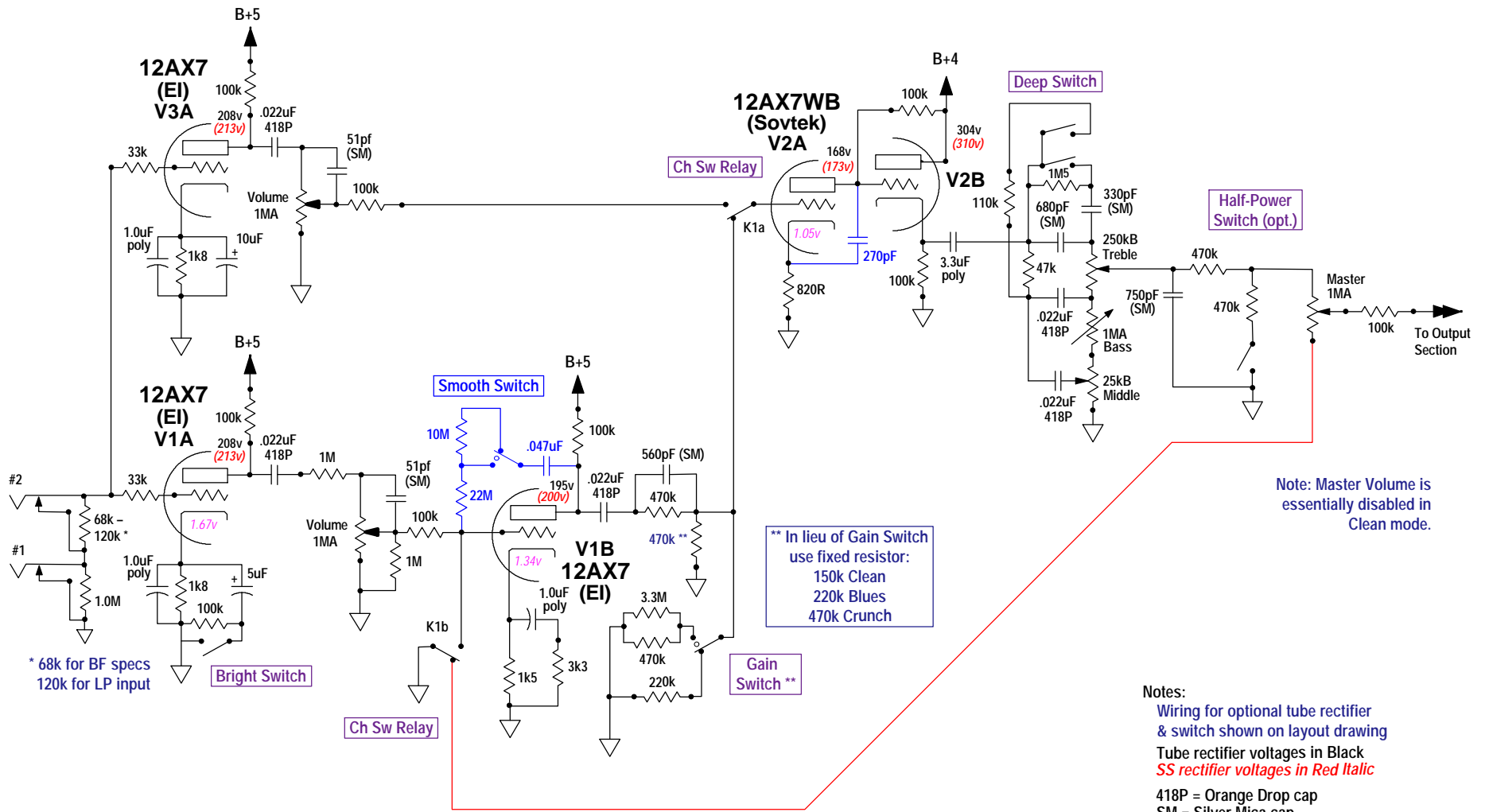

# Hot Rod Tweed Conversion for SF Bassman Head



Channel Switching variation B  
(Preamp section)

Designed by Steve Ahola  
Rev.01-21-00



# Hot Rod Tweed Conversion for SF Bassman Head

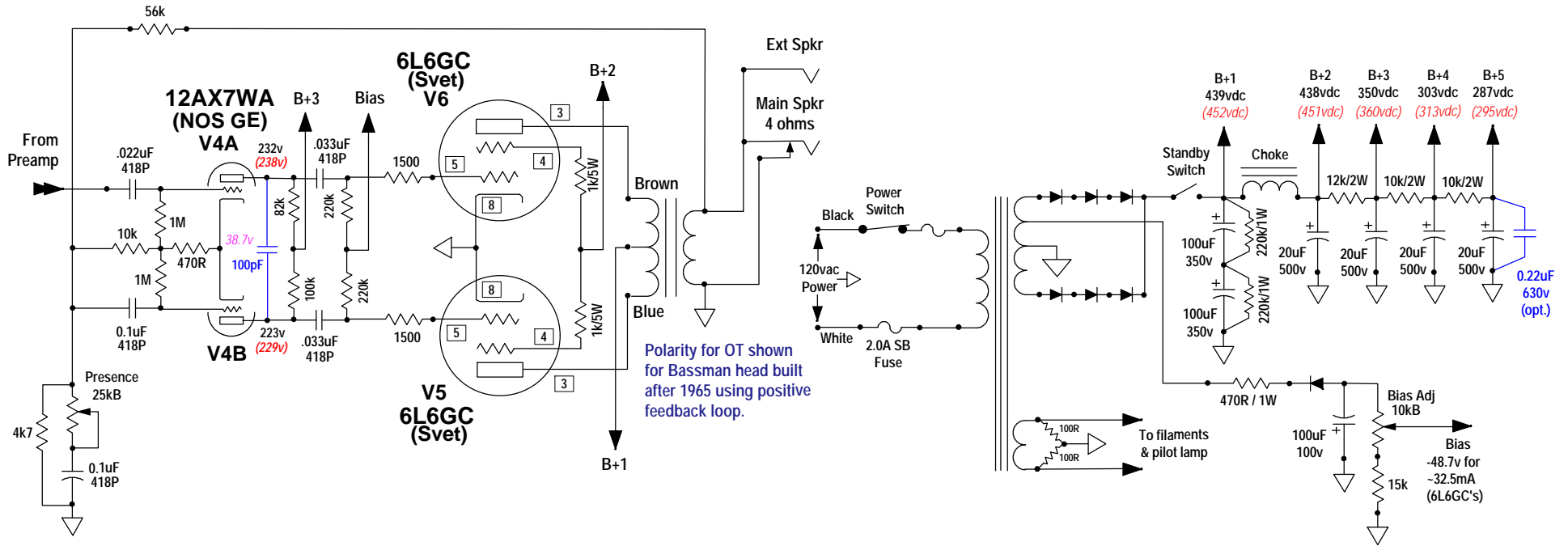

## Notes:

- Wiring for optional tube rectifier & switch shown on layout drawing
- Tube rectifier voltages in Black
- SS rectifier voltages in Red Italic
- 418P = Orange Drop cap
- SM = Silver Mica cap

Channel Switching variation  
(Power amp section)

Designed by Steve Ahola  
Rev.01-21-00