

|  |   |
|--|---|
| <a href="#">Music Electronics Forum</a> > <a href="#">Amplificaton</a> > <a href="#">Guitar Amps</a> > <a href="#">Mods &amp; Tweeks</a><br><b>Musicman RD-50 112 mod</b>  | <b>Welcome, Steve A..</b><br>You last visited: Today at 12:29 PM<br><a href="#">Private Messages</a> : Unread 0, Total 2. |
| <a href="#">Home</a> <a href="#">User CP</a> <a href="#">FAQ</a> <a href="#">Members List</a> <a href="#">Calendar</a> <a href="#">Search</a> <a href="#">New Posts</a> <a href="#">Mark Forums Read</a> <a href="#">Open Buddy List</a> <a href="#">Log Out</a> |   |



[Thread Tools](#)   [Search this Thread](#)   [Rate Thread](#)   [Display Modes](#)

#1 06-26-2006, 09:55 AM

**BobW** Junior Member   Join Date: Jun 2006 Posts: 2

---

**Musicman RD-50 112 mod**

All,  
I'd like to share some of the mods I did to smooth the harsh top end of the Limiter channel typical for Musicman amps. In general, changed the V1a and b stages per the \*umble OD stages.  
In Particular:  
1. disconnected the cathode grounds and ground leads from C10,R12 at V1-8.  
2. Added a 5uf and a 1.8k at V1-8 and connected the grounds to the C10,R12,ground node.  
3. replaced plate resistors R9 (470k) with a 180k, and R11 (4.7M) with a 150k.  
4. replaced R10 with a wire jumper.  
5. removed grin wire at V1-7 and added a 150k series grid resistor.

Initially also added a 470pF across the Clean Vol pot, and a 1000pF across the Limiter Vol Pot to smmoth the harshness at all vol levels in either Clean or Limiter mode.  
The amp is much more useable and it definitely earned it's keep at last weekends gig. BobW

#2 Yesterday, 09:30 AM

**BobW** Junior Member   Join Date: Jun 2006 Posts: 2

No replies? I guess no one else has an RD-50?



[« Previous Thread](#) | [Next Thread »](#)

**Quick Reply**

The following errors occurred when this message was submitted

[Okay](#)

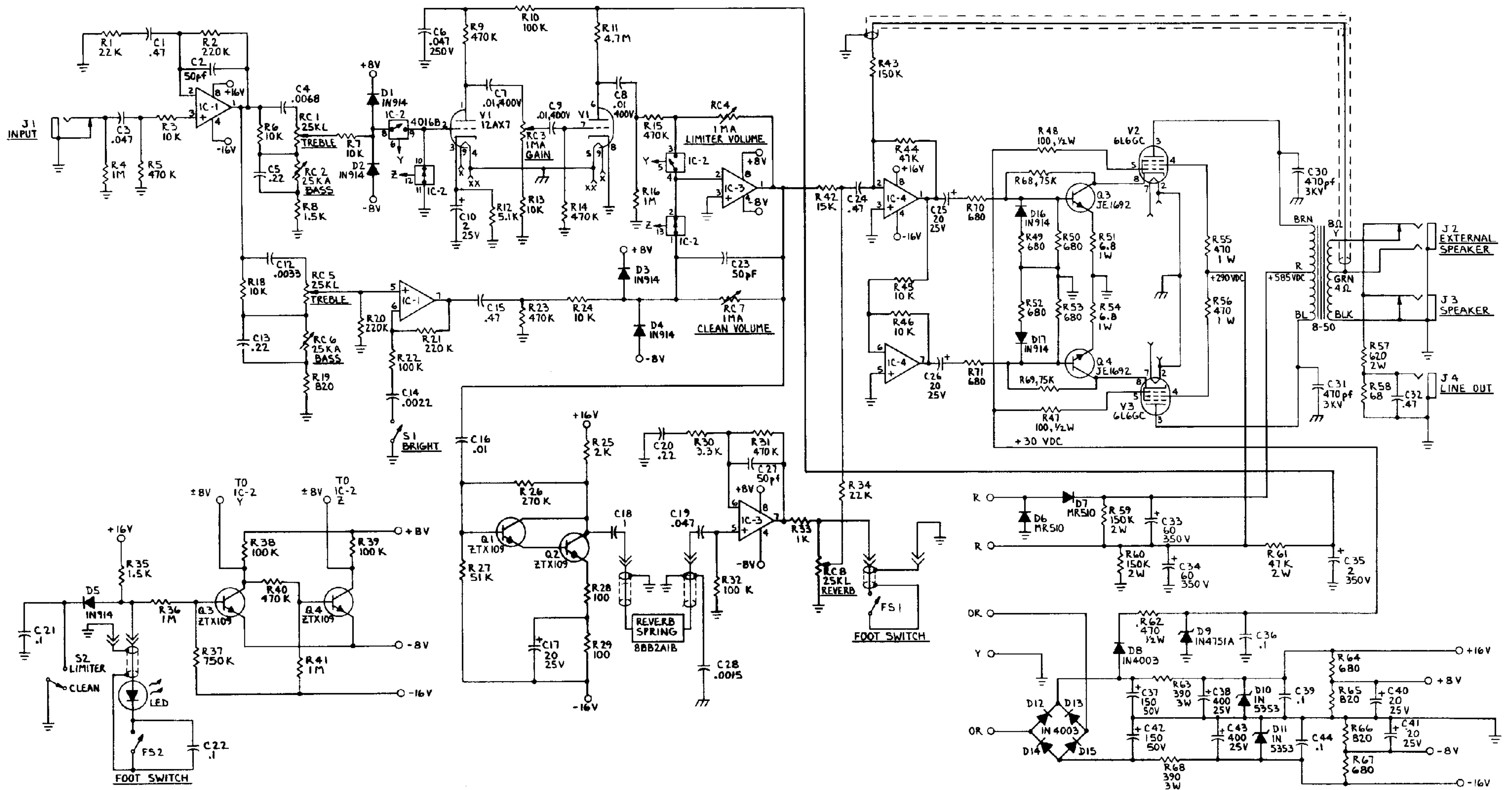

GRN ○ → x  
GRN ○ → xx

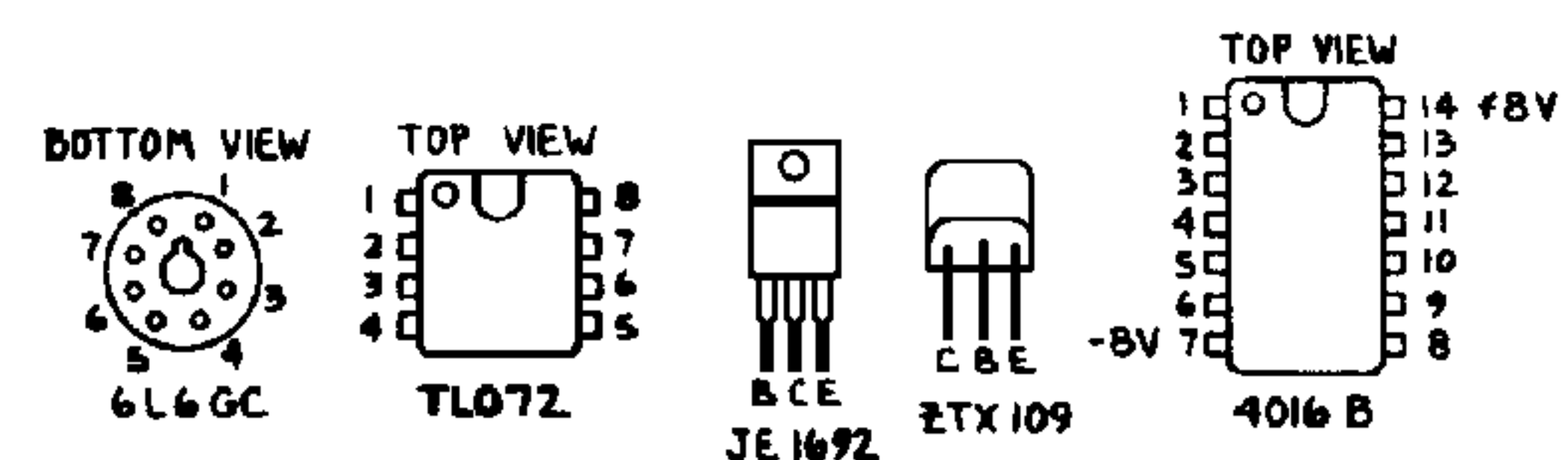

5. +8V & -8V ARE NOMINAL; ACTUAL VOLTAGE MAY VARY ± 1 VOLT.  
 4. IC-2 IS 4016B.  
 3. IC'S 1,3,&4 ARE TL072.  
 2. ALL CAPACITANCE VALUES ARE IN MICROPARADS (μF) EXCEPT WHERE NOTED.  
 NOTE: 1. ALL RESISTANCE VALUES ARE IN OHMS (Ω), 1/4 WATT, EXCEPT WHERE NOTED.

|  |   |
|--|---|
| DRAWN<br><i>J. McCarty 9-3-80</i><br>CHECKED<br><i>T. Walker 9-10</i><br>DESIGNED<br><i>T. Walker</i><br>APPROVED<br><i>T. Walker</i><br>APPROVED<br><i>WJ</i> | MUSIC MAN INC. ANAHEIM, CA.<br><br>SCHEMATIC DIAGRAM -<br>RD-50 AMPLIFIER<br><br>SCALE<br>DWG. NO. 5004<br>REV. A<br>SHEET 1 OF 1 |
|--|---|